

RGS 60

Cable tray, heavy, perforated, height=60 mm

Cable tray, heavy, perforated, head shape suitable for positive locking covers, with longitudinal and lateral reinforcing rims reducing bottom deflection, certified including electrical conductivity according to DIN EN 61537. Side and bottom connectors are provided for assembly. Cable load as standard support construction max. 10 kg/m with 1.2 m support spacing. The product can be used for fire protection. For technical parameters, see National Technical Test Certificates (abPs).



© EL-PUK Sp. z o.o. • MP • EN • 2025-04-22

Continuously hot galvanized (Sendzimir process) (DIN EN 10346)

Product	H	B	L	A	Q _{SK}	t	G
RGS 60-05S	60 mm	50 mm	3000 mm	30 cm ²	0,04 kN/m	1,50 mm	6,20 kg
RGS 60-10S	60 mm	100 mm	3000 mm	56 cm ²	0,09 kN/m	1,50 mm	7,90 kg
RGS 60-20S	60 mm	200 mm	3000 mm	113 cm ²	0,17 kN/m	1,50 mm	11,20 kg
RGS 60-30S	60 mm	300 mm	3000 mm	171 cm ²	0,26 kN/m	1,50 mm	14,50 kg
RGS 60-40S	60 mm	400 mm	3000 mm	228 cm ²	0,34 kN/m	1,50 mm	17,80 kg
RGS 60-50S	60 mm	500 mm	3000 mm	286 cm ²	0,43 kN/m	1,50 mm	21,80 kg
RGS 60-60S	60 mm	600 mm	3000 mm	343 cm ²	0,52 kN/m	1,50 mm	25,10 kg

Hot-dip galvanized, according to BS 729 (DIN EN ISO 1461)

Product	H	B	L	A	Q _{SK}	t	G
RGS 60-05F	60 mm	50 mm	3000 mm	30 cm ²	0,04 kN/m	1,50 mm	7,00 kg
RGS 60-10F	60 mm	100 mm	3000 mm	56 cm ²	0,09 kN/m	1,50 mm	8,80 kg
RGS 60-20F	60 mm	200 mm	3000 mm	113 cm ²	0,17 kN/m	1,50 mm	12,60 kg
RGS 60-30F	60 mm	300 mm	3000 mm	171 cm ²	0,26 kN/m	1,50 mm	16,30 kg
RGS 60-40F	60 mm	400 mm	3000 mm	228 cm ²	0,34 kN/m	1,50 mm	20,00 kg
RGS 60-50F	60 mm	500 mm	3000 mm	286 cm ²	0,43 kN/m	1,50 mm	24,40 kg
RGS 60-60F	60 mm	600 mm	3000 mm	343 cm ²	0,52 kN/m	1,50 mm	28,10 kg





Stainless steel, according to ASTM 304 / BS 304 S 3

Product	H	B	L	A	Q_{sk}	t	G
RGS 60-05E	60 mm	50 mm	3000 mm	30 cm ²	0,04 kN/m	1,50 mm	6,20 kg
RGS 60-10E	60 mm	100 mm	3000 mm	56 cm ²	0,09 kN/m	1,50 mm	7,90 kg
RGS 60-20E	60 mm	200 mm	3000 mm	113 cm ²	0,17 kN/m	1,50 mm	11,20 kg
RGS 60-30E	60 mm	300 mm	3000 mm	171 cm ²	0,26 kN/m	1,50 mm	14,50 kg
RGS 60-40E	60 mm	400 mm	3000 mm	228 cm ²	0,34 kN/m	1,50 mm	17,80 kg
RGS 60-50E	60 mm	500 mm	3000 mm	286 cm ²	0,43 kN/m	1,50 mm	21,80 kg
RGS 60-60E	60 mm	600 mm	3000 mm	343 cm ²	0,52 kN/m	1,50 mm	25,10 kg

Stainless steel, material no. 1.4571 (ANSI 316 Ti) / 1.4404 (ANSI 316 L)

Product	H	B	L	A	Q_{sk}	t	G
RGS 60-05E4	60 mm	50 mm	3000 mm	30 cm ²	0,04 kN/m	1,50 mm	6,20 kg
RGS 60-10E4	60 mm	100 mm	3000 mm	56 cm ²	0,09 kN/m	1,50 mm	7,90 kg
RGS 60-20E4	60 mm	200 mm	3000 mm	113 cm ²	0,17 kN/m	1,50 mm	11,20 kg
RGS 60-30E4	60 mm	300 mm	3000 mm	171 cm ²	0,26 kN/m	1,50 mm	14,50 kg
RGS 60-40E4	60 mm	400 mm	3000 mm	228 cm ²	0,34 kN/m	1,50 mm	17,80 kg
RGS 60-50E4	60 mm	500 mm	3000 mm	286 cm ²	0,43 kN/m	1,50 mm	21,80 kg
RGS 60-60E4	60 mm	600 mm	3000 mm	343 cm ²	0,52 kN/m	1,50 mm	25,10 kg

Coating Magnelis[®] according to DIN EN 10346

Product	H	B	L	A	Q_{sk}	t	G
RGS 60-05ZM	60 mm	50 mm	3000 mm	30 cm ²	0,04 kN/m	1,50 mm	6,20 kg
RGS 60-10ZM	60 mm	100 mm	3000 mm	56 cm ²	0,09 kN/m	1,50 mm	7,90 kg
RGS 60-20ZM	60 mm	200 mm	3000 mm	113 cm ²	0,17 kN/m	1,50 mm	11,20 kg
RGS 60-30ZM	60 mm	300 mm	3000 mm	171 cm ²	0,26 kN/m	1,50 mm	14,50 kg
RGS 60-40ZM	60 mm	400 mm	3000 mm	228 cm ²	0,34 kN/m	1,50 mm	17,80 kg
RGS 60-50ZM	60 mm	500 mm	3000 mm	286 cm ²	0,43 kN/m	1,50 mm	21,80 kg
RGS 60-60ZM	60 mm	600 mm	3000 mm	343 cm ²	0,52 kN/m	1,50 mm	25,10 kg



- H** : Height
- B** : Width
- L** : Length
- t** : Material thickness
- A** : Cross section area
- Q_{sk}** : Distributed load control cable
- G** : Weight

DETAILS / APPLICATIONS

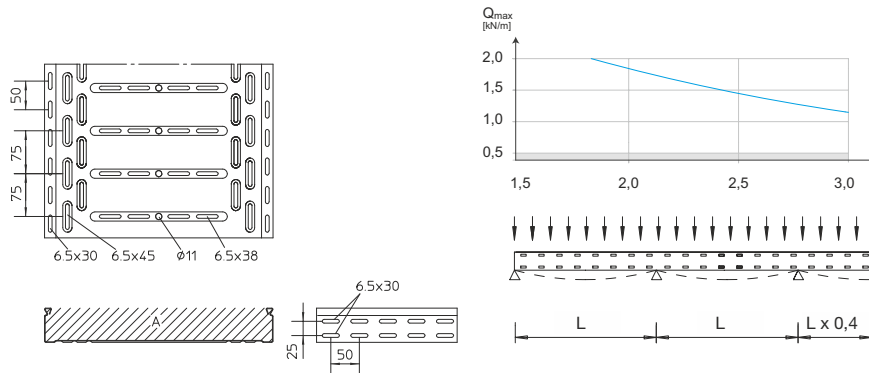

OPTIONAL ACCESSORIES

RB 60, RB45 60, RAE 60, RAA 60, RA 60, RK 60, RVB 60, RR 60, RAB 60, REB, RGV 60, RGVS, VB, RTR 60, KLR



Do not walk upon!



TÜV certified



Certified according to Det Norske Veritas (DNV) and Germanischer Lloyd (GL)



Certyfikat UL



System E 90. CNBOP-PIB

